

Equilong BUS  
ZO= 50 ohm

CPU-A

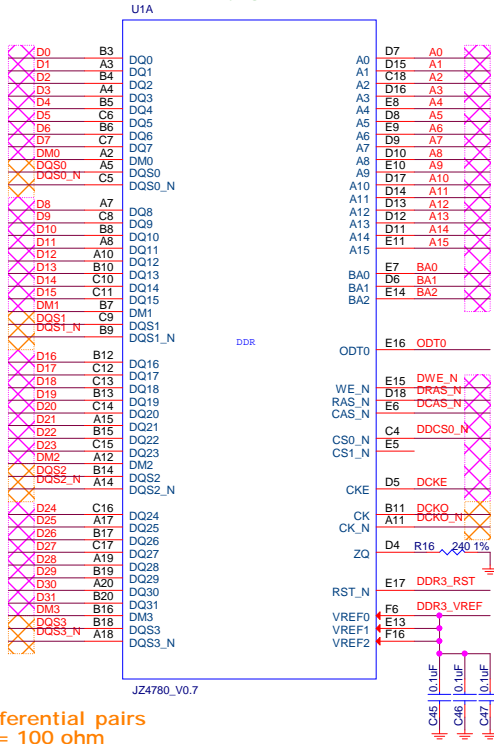

J24780\_V0.7

Differential pairs  
ZO= 100 ohm

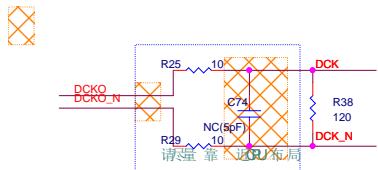

请尽量靠近CPU布局

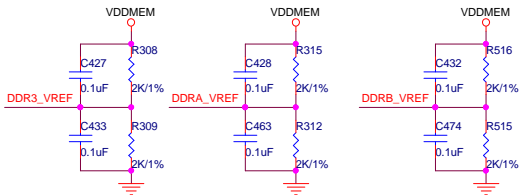

The trace DDR\_VREF is 20 mils wide at least.

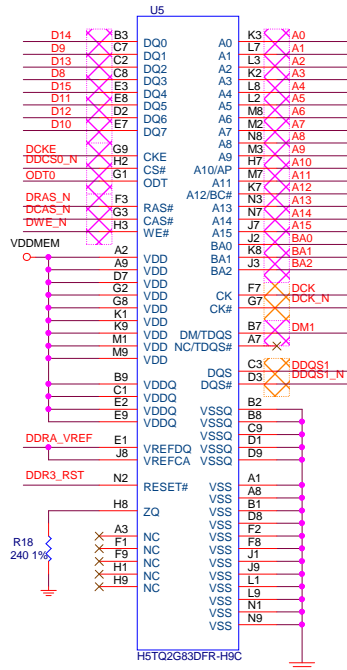
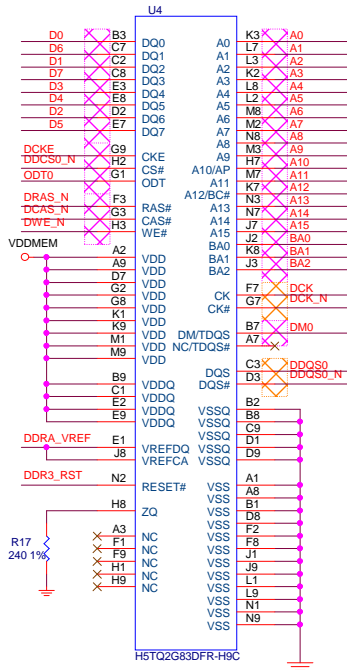

DDR3

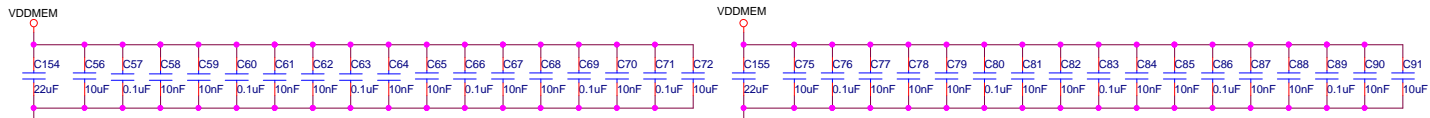
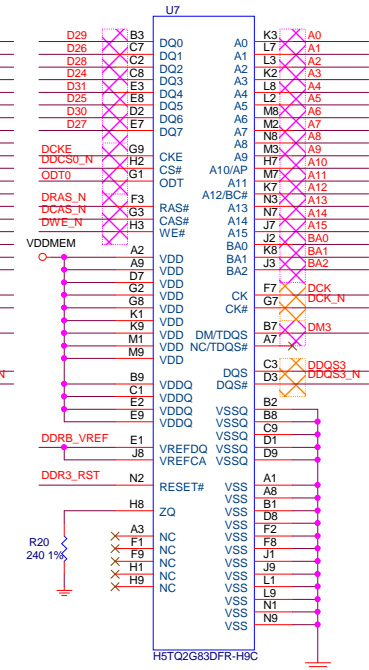
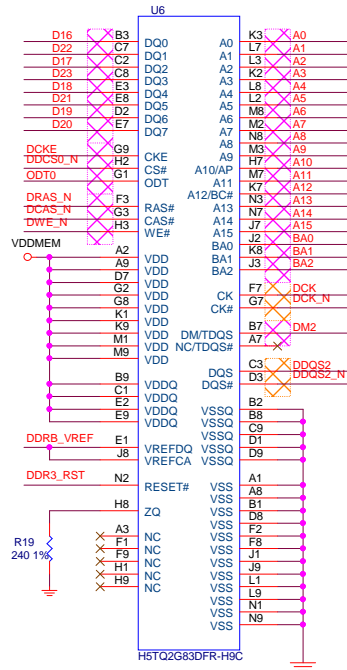

MEM Power Decoupling Capacitors  
Place near The Power Pins as Close as Possible

Layout时尽量靠近CPU布局,并给DDR3电源管脚放置一个去耦电容.

DDR Power Decoupling Capacitors

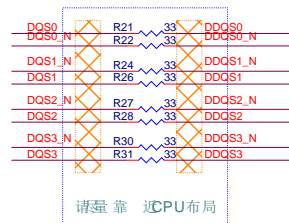

请尽量靠近CPU布局

INGENIC SEMICONDUCTOR CO.,LTD

Title		
C120_JZ4780		
Size	Document Number	Rev
A3	MEMORY_DDR3x4	V1.0
Date:	Thursday, June 19, 2014	Sheet 1 of 10

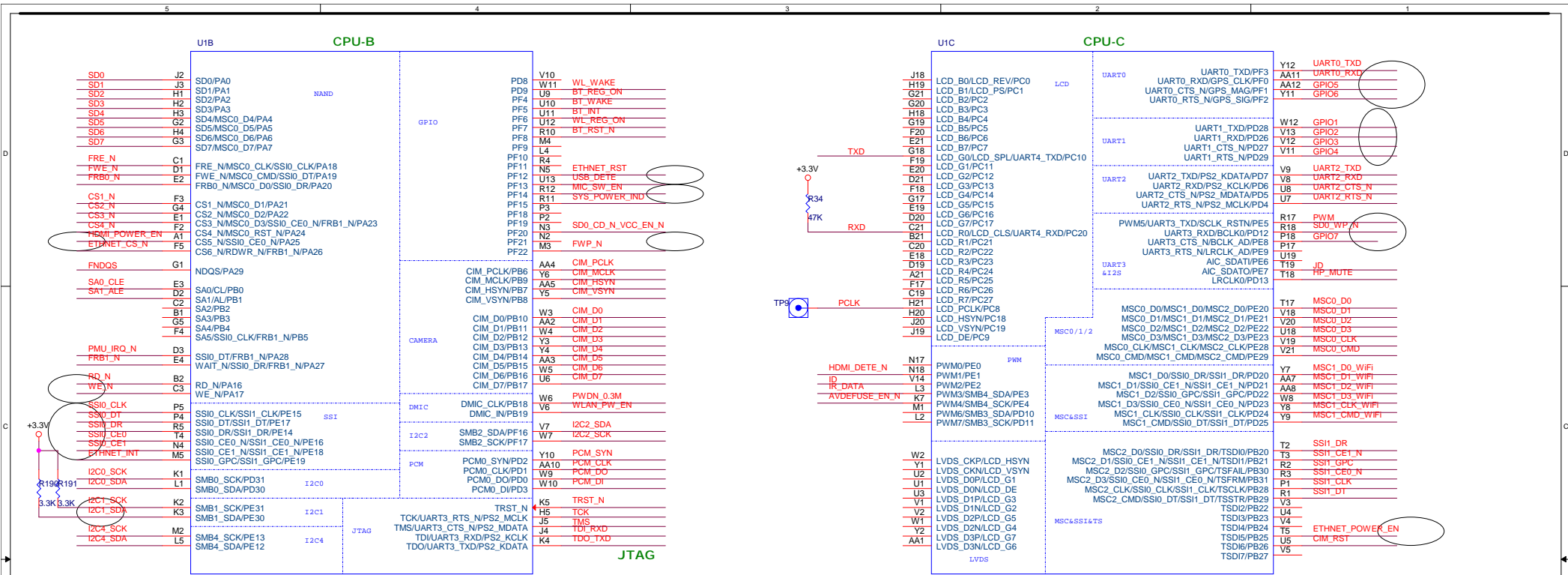

JZ4780\_V0.7

JZ4780\_V0.7

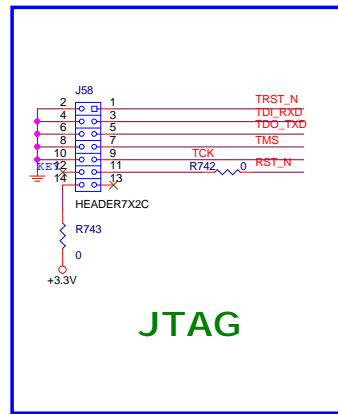
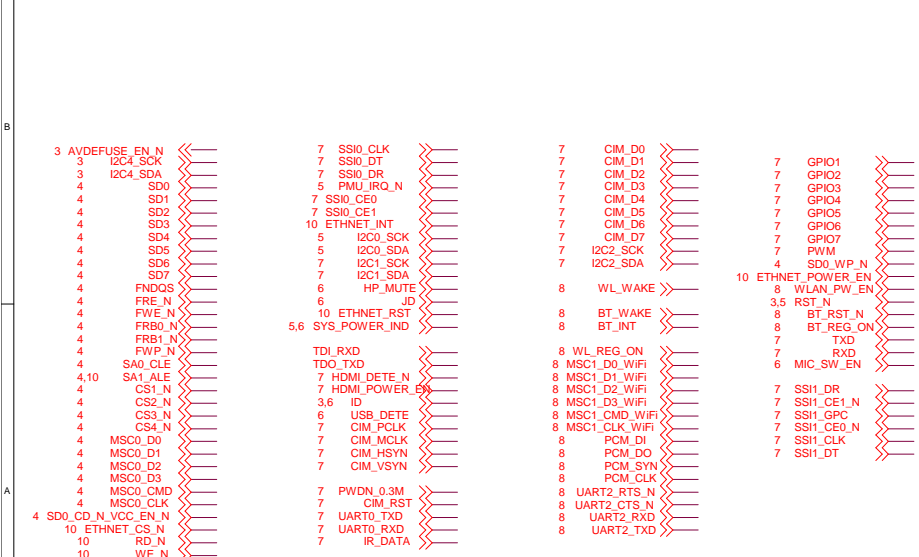

JTAG

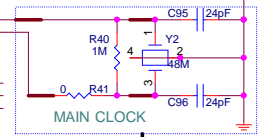
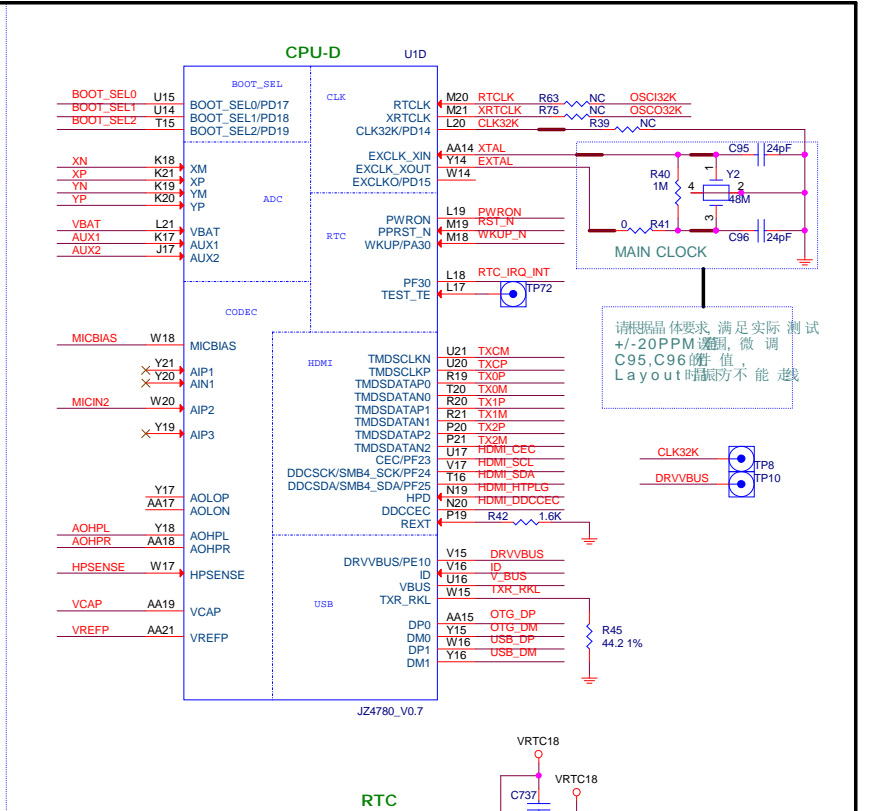
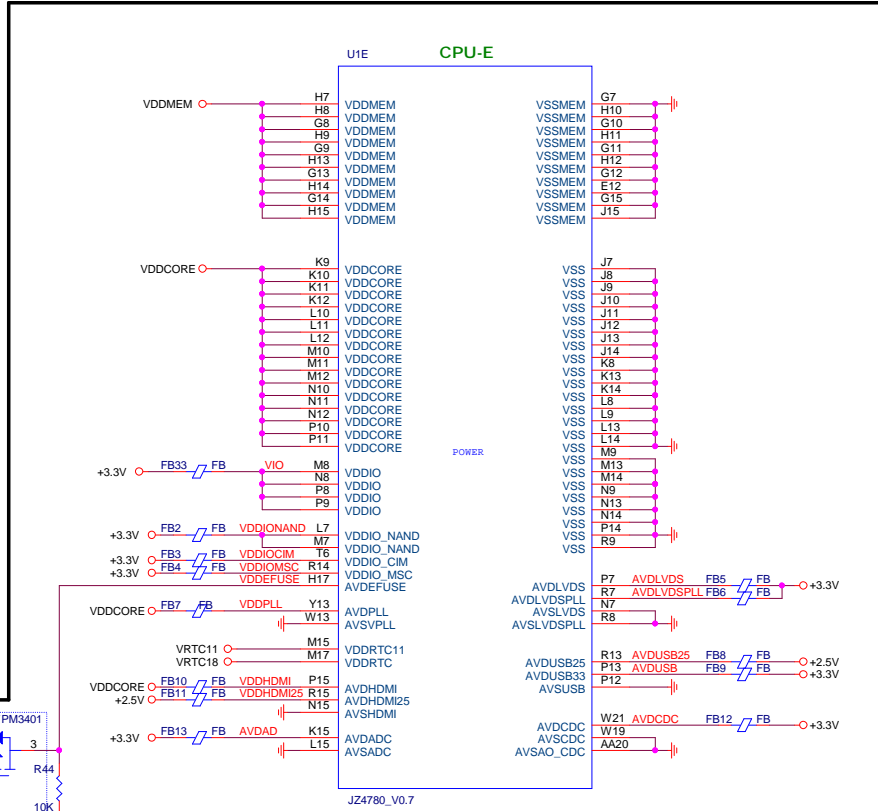
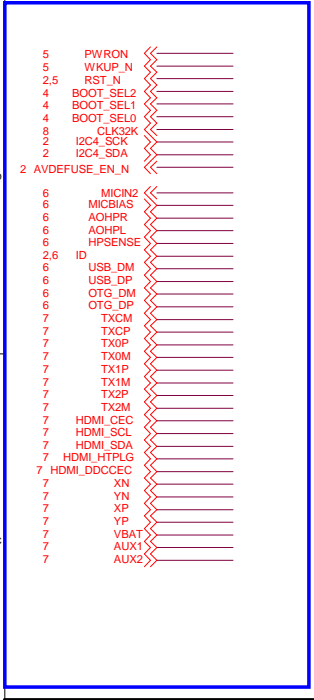

请根据晶体要求, 满足实际测试 +/-20PPM 误差, 微调 C95, C96 值, Layout 时阻抗不能走线

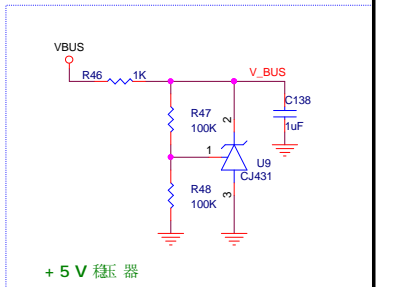
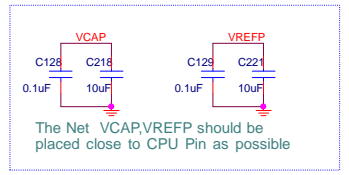
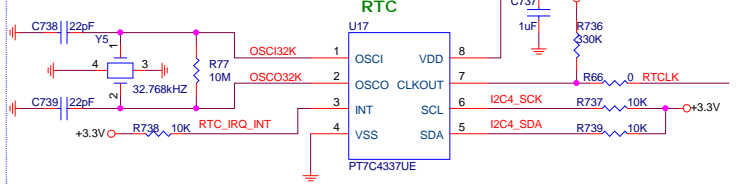
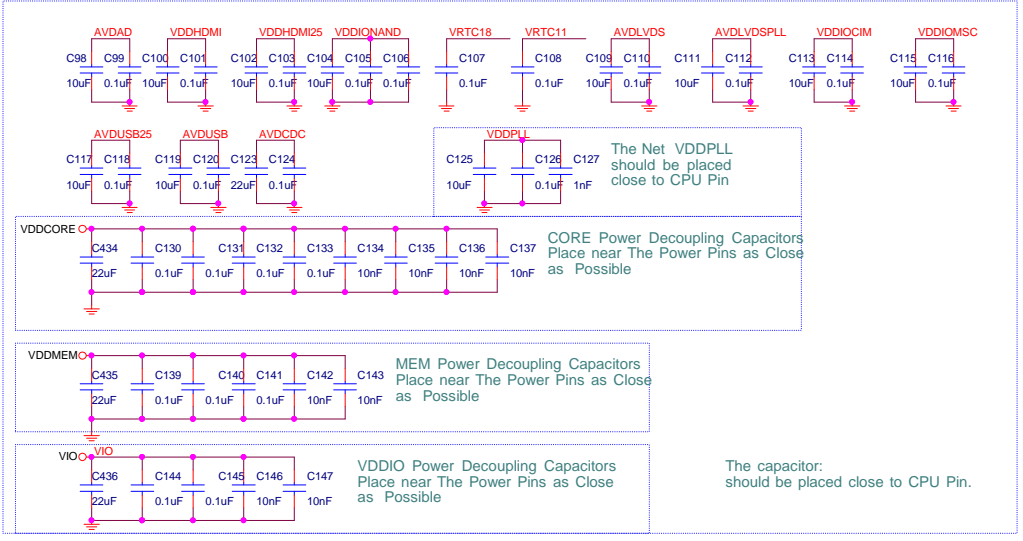
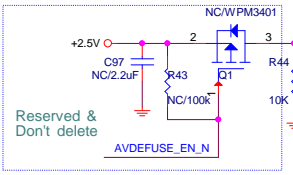
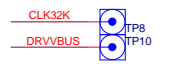

Surround with Gnd

<b>INGENIC SEMICONDUCTOR CO.,LTD</b>		
Title	C120_JZ4780	
Size	Document Number	Rev
A3	4780_Power_RTC	V1.0
Date:	Thursday, June 19, 2014	Sheet 3 of 10



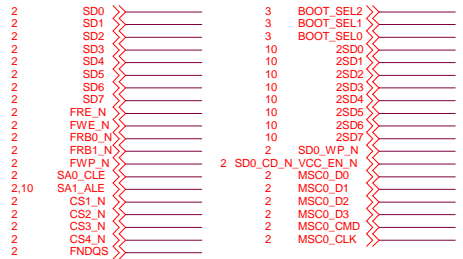
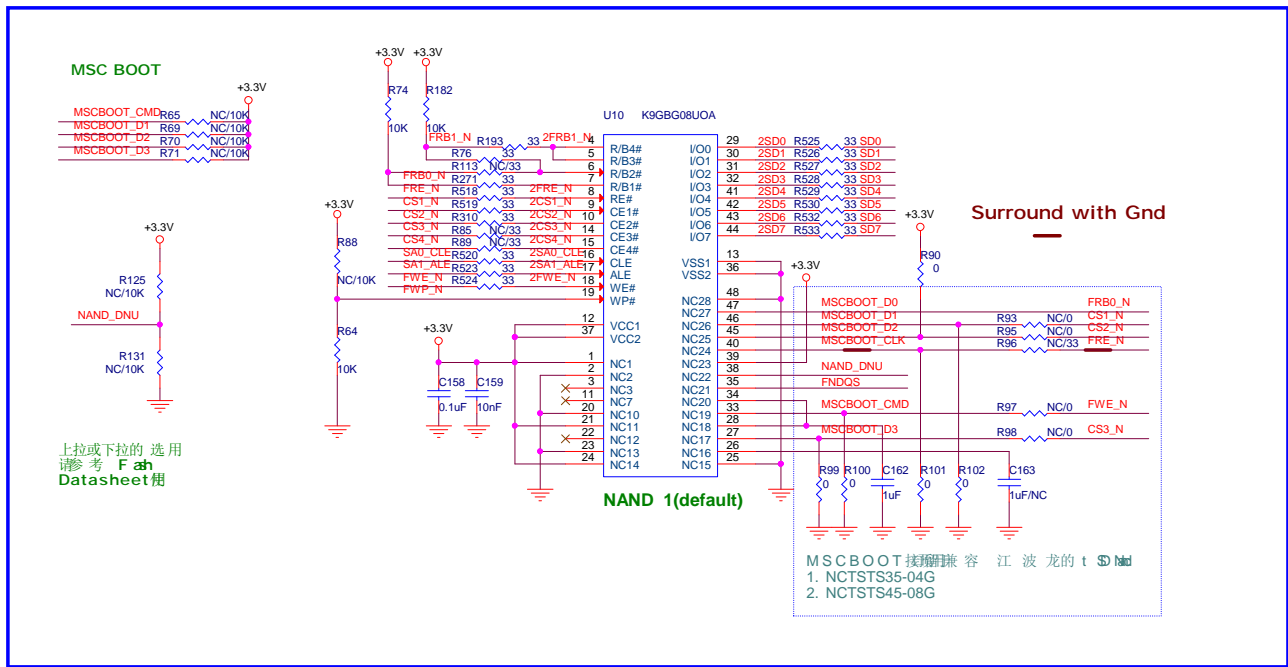
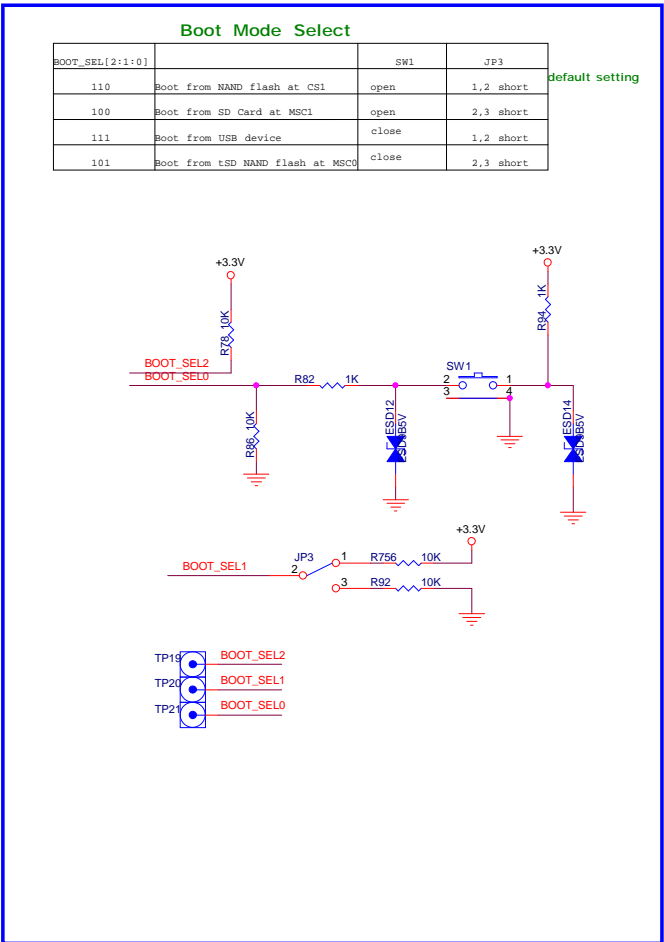
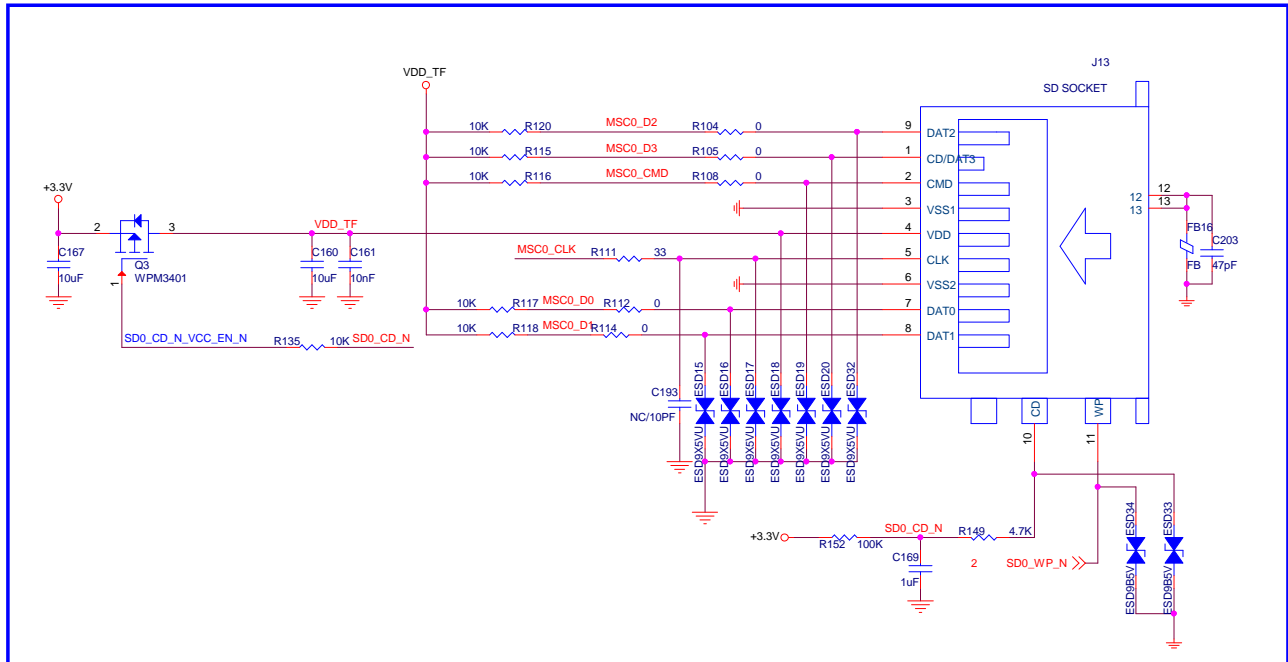

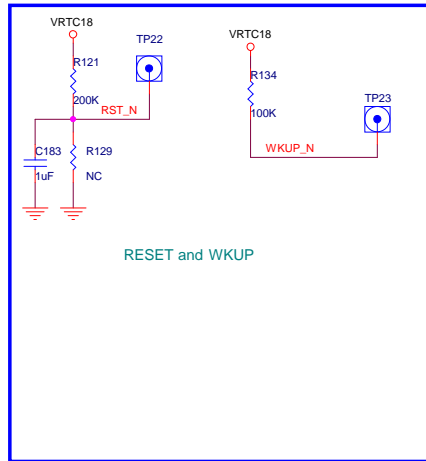
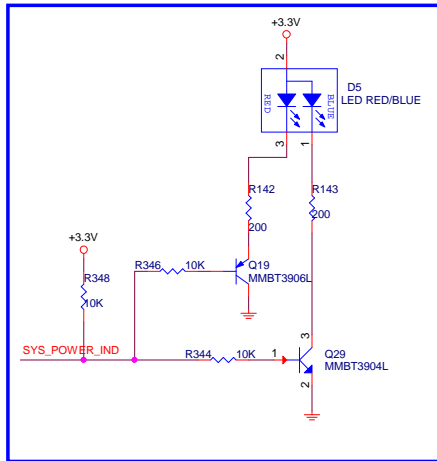
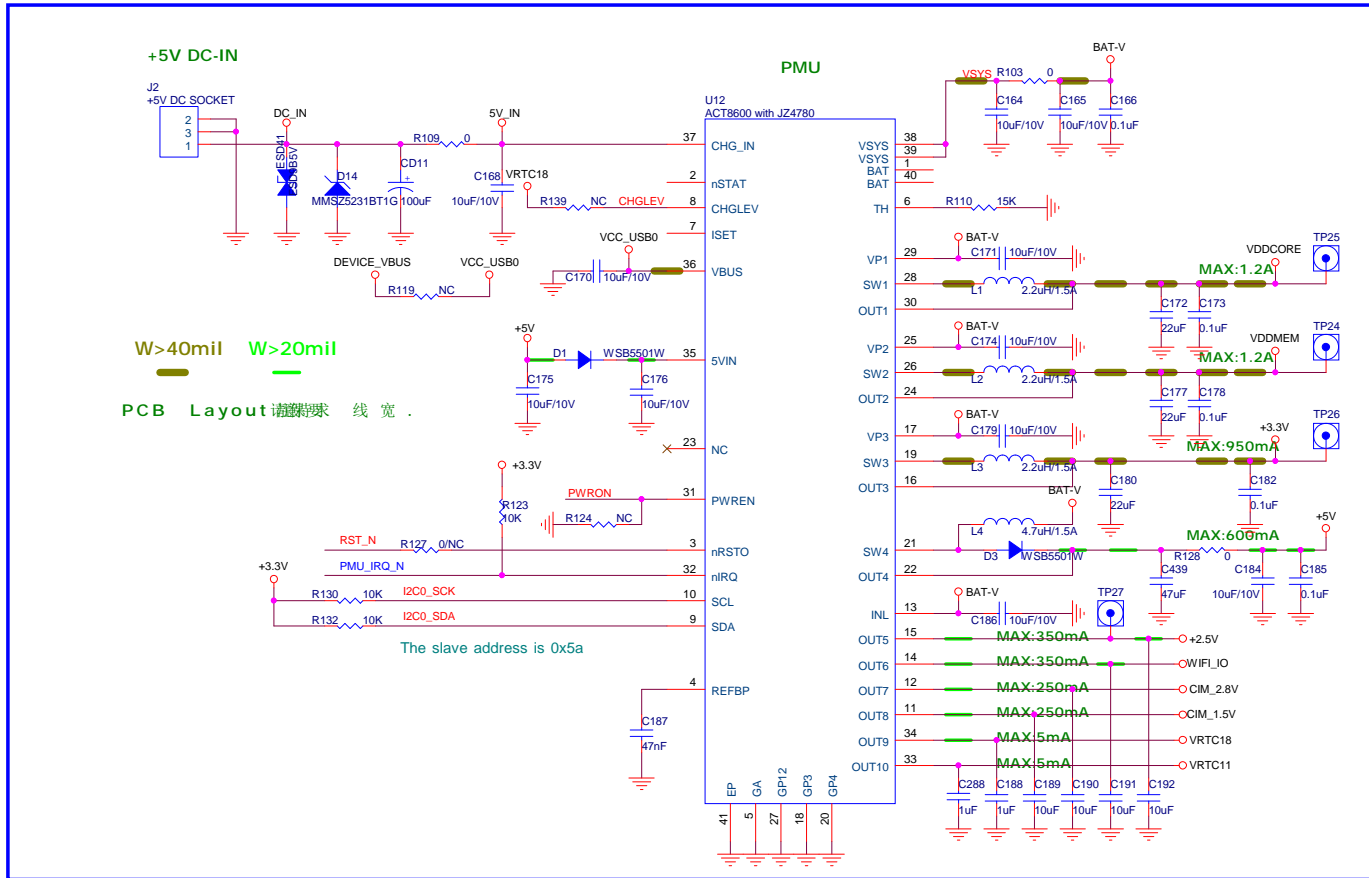

<b>INGENIC SEMICONDUCTOR CO.,LTD</b>		
Title	C120_JZ4780	
Size	Document Number	Rev
A3	PMU/LED/RST	V1.0
Date:	Thursday, June 19, 2014	Sheet 5 of 10

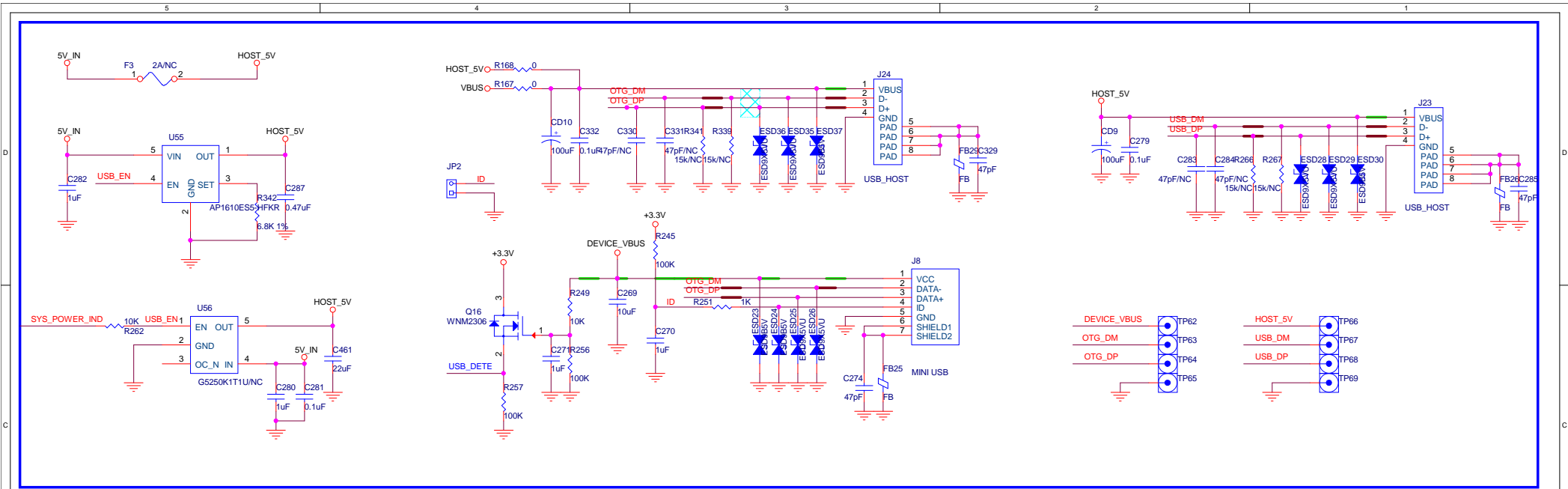

**Surround with Gnd**

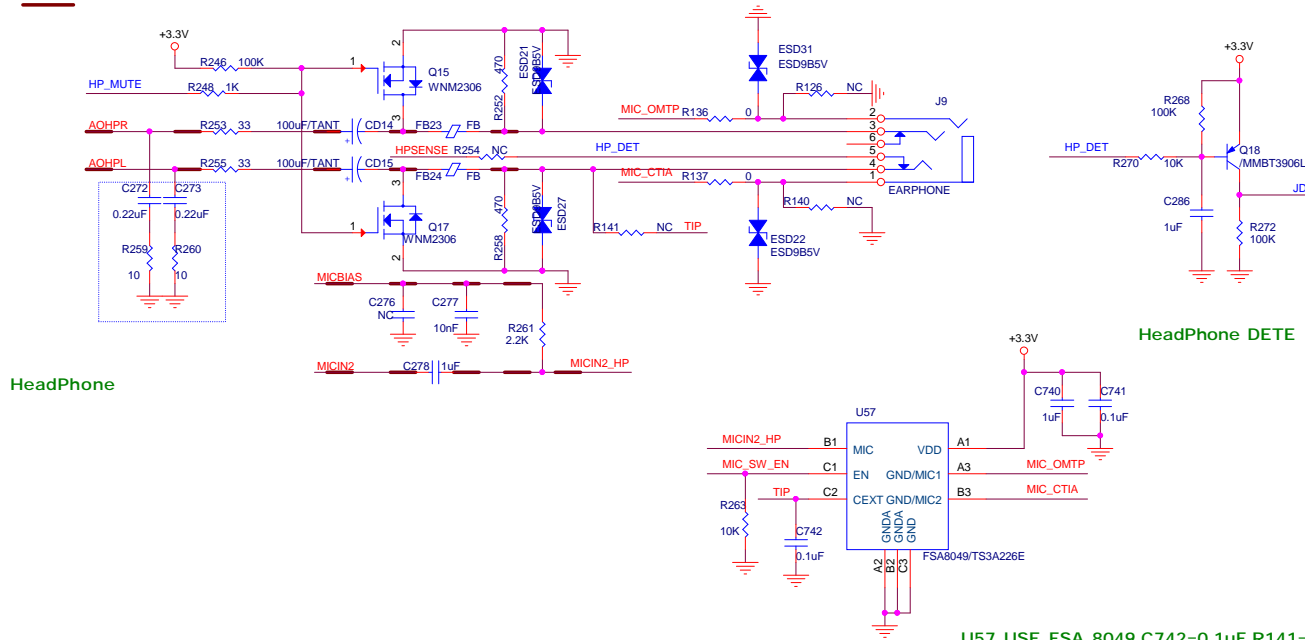

U57 USE FSA 8049,C742=0.1uF,R141=NC  
 U57 USE TS3A226E,C742=NC,R141=0

- 3 MICBIAS
- 3 AOHPR
- 3 AOHPL
- 3 HPSENSE
- 2 HP\_MUTE
- 2 JD
- 2 USB\_DET
- 3 OTG\_DM
- 3 OTG\_DP
- 2.5 SYS\_POWER\_IND
- 3 USB\_DM
- 3 USB\_DP
- 3 MICIN2
- 2 MIC\_SW\_EN

<b>INGENIC SEMICONDUCTOR CO.,LTD</b>		
Title	C120_JZ4780	
Size	Document Number	Rev
A3	USB Power/AUDIO	V1.0
Date:	Thursday, June 19, 2014	Sheet 6 of 10

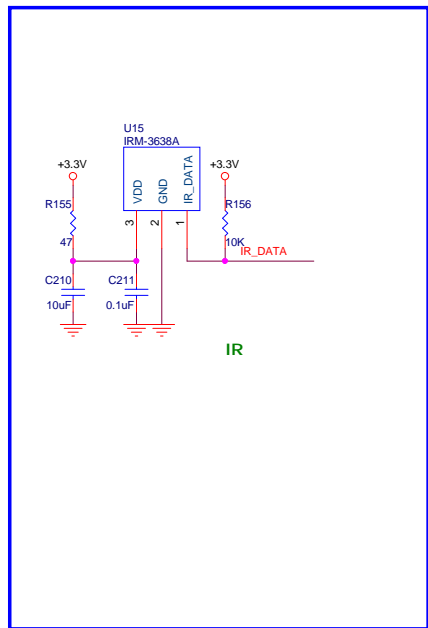
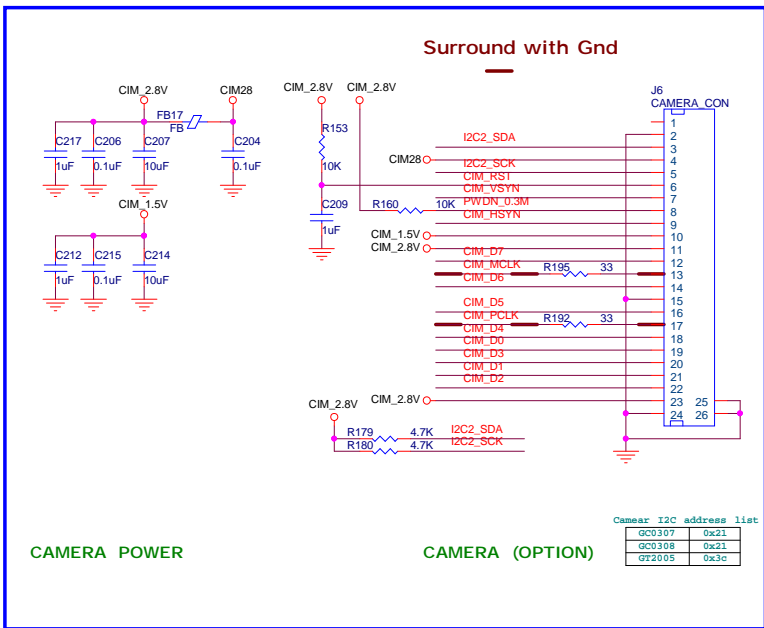
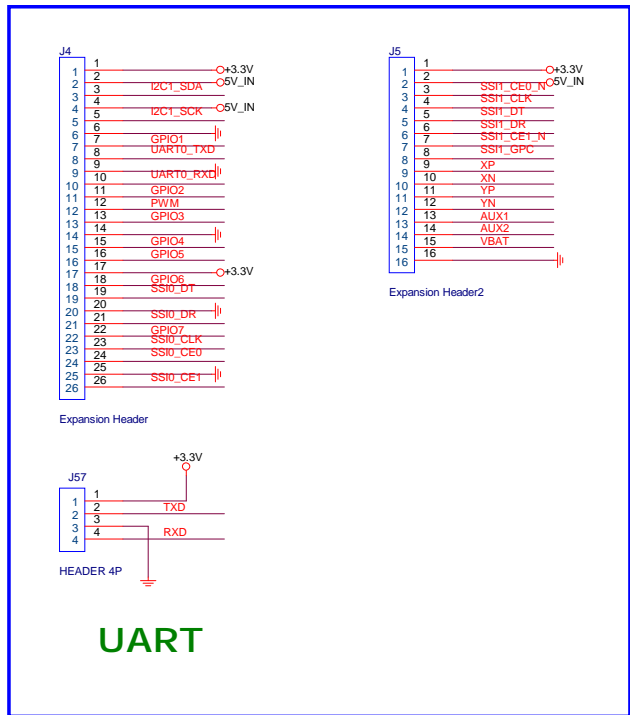
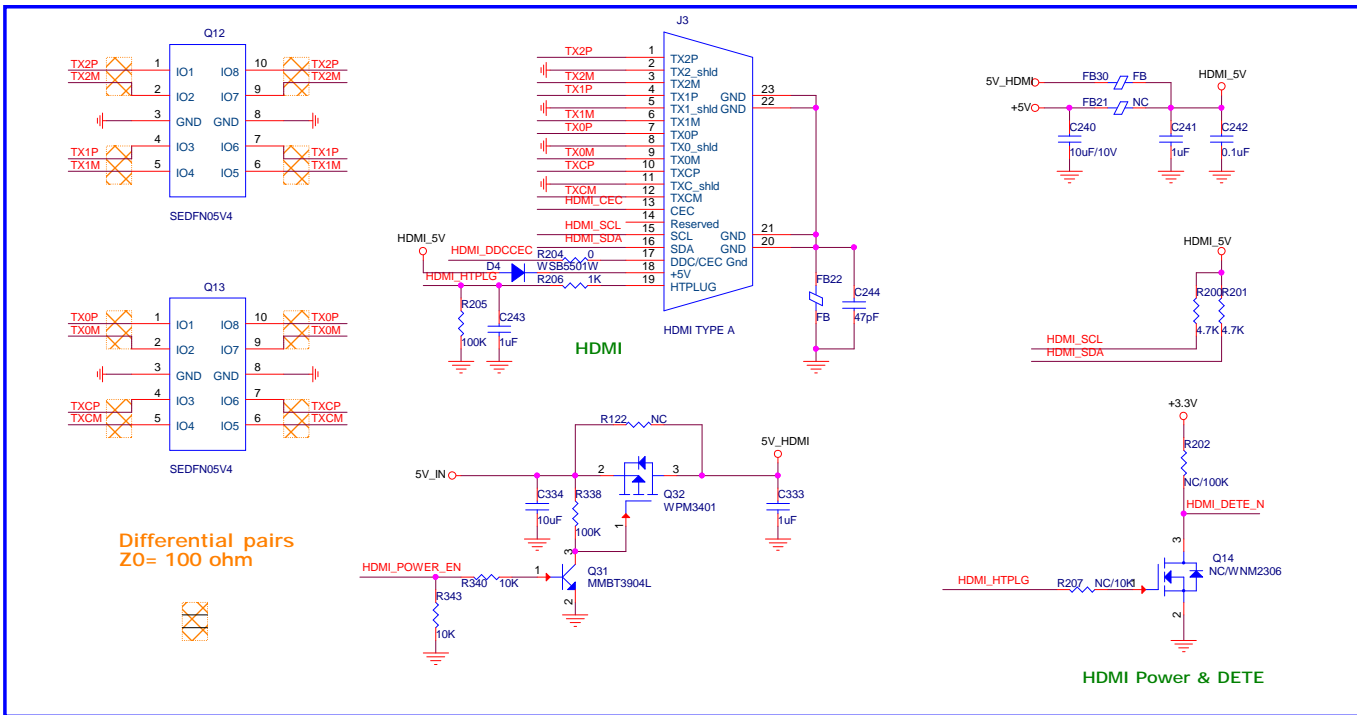

- |                 |              |
|-----------------|--------------|
| 2 SSIO_CLK      | 2 PWDN_0.3M  |
| 2 SSIO_DT       | 2 TXD        |
| 2 SSIO_DR       | 2 RXD        |
| 2 SSIO_CE0      | 2 CIM_PCLK   |
| 2 SSIO_CE1      | 2 CIM_MCLK   |
| 2 TDI_RXD       | 2 CIM_HSYN   |
| 2 TDO_TXD       | 2 CIM_VSYN   |
| 2 PWM           | 2 CIM_D0     |
| 2 UART0_TXD     | 2 CIM_D1     |
| 2 UART0_RXD     | 2 CIM_D2     |
| 2 GPIO1         | 2 CIM_D3     |
| 2 GPIO2         | 2 CIM_D4     |
| 2 GPIO3         | 2 CIM_D5     |
| 2 GPIO4         | 2 CIM_D6     |
| 2 GPIO5         | 2 CIM_D7     |
| 2 GPIO6         | 2 I2C2_SCK   |
| 2 GPIO7         | 2 I2C2_SDA   |
| 2 I2C1_SCK      | 2 CIM_RST    |
| 2 I2C1_SDA      | 2 IR_DATA    |
| 3 TXCM          | 2 SS11_DR    |
| 3 TXCP          | 2 SS11_CET_N |
| 3 TX0P          | 2 SS11_GPC   |
| 3 TX0M          | 2 SS11_CE0_N |
| 3 TX1P          | 2 SS11_CLK   |
| 3 TX1M          | 2 SS11_DT    |
| 3 TX2P          | 3 XN         |
| 3 TX2M          | 3 YN         |
| 3 HDMI_CEC      | 3 XP         |
| 3 HDMI_SCL      | 3 YP         |
| 3 HDMI_SDA      | 3 VBAT       |
| 3 HDMI_HTPLG    | 3 AUX1       |
| 3 HDMI_DDCCEC   | 3 AUX2       |
| 2 HDMI_DET_N    |              |
| 2 HDMI_POWER_EN |              |

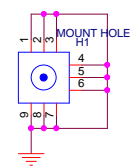

2 MSC1\_D0\_WIFI >>>  
 2 MSC1\_D1\_WIFI >>>  
 2 MSC1\_D2\_WIFI >>>  
 2 MSC1\_D3\_WIFI >>>  
 2 MSC1\_CMD\_WIFI >>>  
 2 MSC1\_CLK\_WIFI >>>  
 3 CLK32K >>>

2 WL\_REG\_ON >>>  
 2 WLAN\_PW\_EN >>>  
 2 PCM\_DI >>>  
 2 PCM\_DO >>>  
 2 PCM\_SYN >>>  
 2 PCM\_CLK >>>  
 2 BT\_WAKE >>>  
 2 WL\_WAKE >>>  
 2 BT\_INT >>>  
 2 UART2\_RTS\_N >>>  
 2 UART2\_CTS\_N >>>  
 2 UART2\_RXD >>>  
 2 UART2\_TXD >>>  
 2 BT\_RST\_N >>>  
 2 BT\_REG\_ON >>>

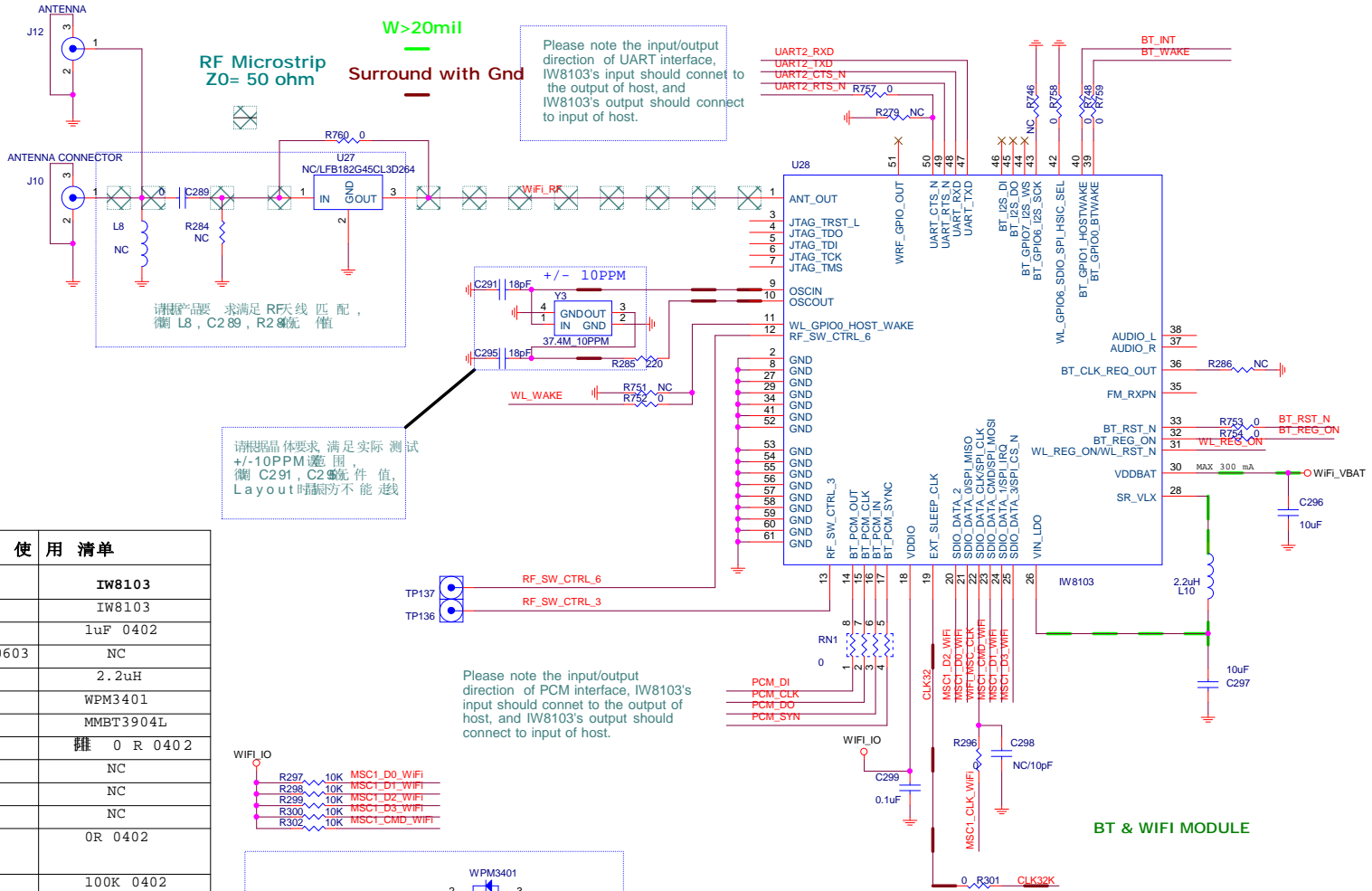

请根据晶振要求满足实际测试  
 +/-10PPM范围  
 晶振 C291, C295 元件值,  
 Layout 时阻抗不能超限

Please note the input/output  
 direction of PCM interface, IW8103's  
 input should connect to the output of  
 host, and IW8103's output should  
 connect to input of host.

EXT\_SLEEP\_CLK 200- 1800 mV p-p to  
 avoid additional current consumption  
 and degradation in FM SNR. 3.3V Vp-p  
 maximum.

IW8101/IW8103 器件使用清单		
器件编号	IW8101	IW8103
U28	IW8101	IW8103
C300	NC	1uF 0402
FB28	75@100MHz 0603	NC
L10	1.5uH	2.2uH
Q21	NC	WPM3401
Q22	NC	MMBT3904L
RN1	NC	0R 0402
R279	100K 0402	NC
R746	0R 0402	NC
R751	0R 0402	NC
R757,R748,R759 ,R752,R753,R754	NC	0R 0402
R303	NC	100K 0402
R305	NC	10K 0402
R304	NC	1K 0402
U27	U27 LFB182G45CL3D264	R760,0
Y3	26MHz +/-10ppm	37.4MHz +/-10ppm

备注:  
 1. 原图参考设计为 IW8101 设计。  
 2. 清单内无标注器件值为 WIFI 共用物料, 请按原理图  
 标示值进行选择。  
 3. 如使用 IW8103, 则 WIFI 电压应调整为 2.8V 或 2.9V,  
 同时系统电压也相应调整为 2.8V 或 2.9V

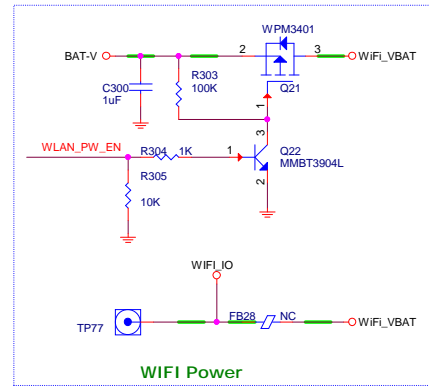

INGENIC SEMICONDUCTOR CO.,LTD		
Title	CI20_JZ4780	
Size	Document Number	Rev
A3	WiFi-IW8101/IW8103	V1.0
Date:	Thursday, June 19, 2014	Sheet 8 of 10



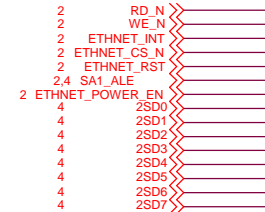
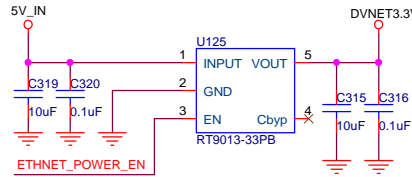
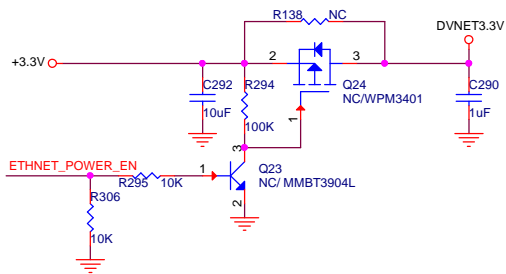
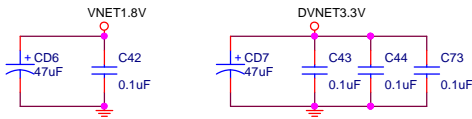
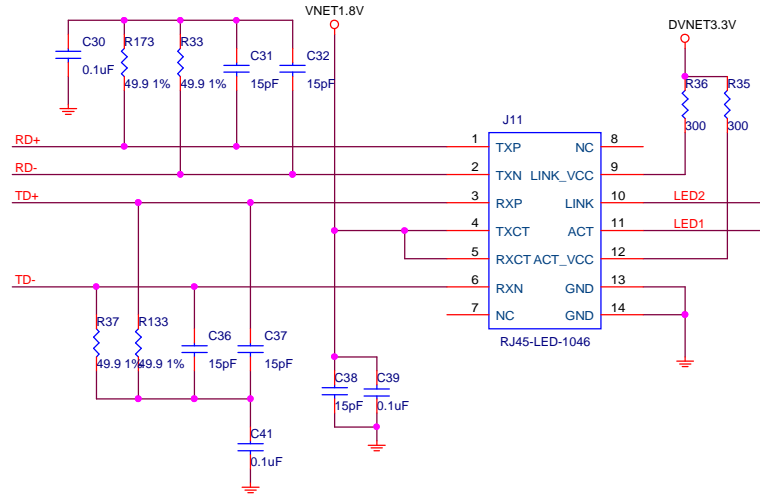
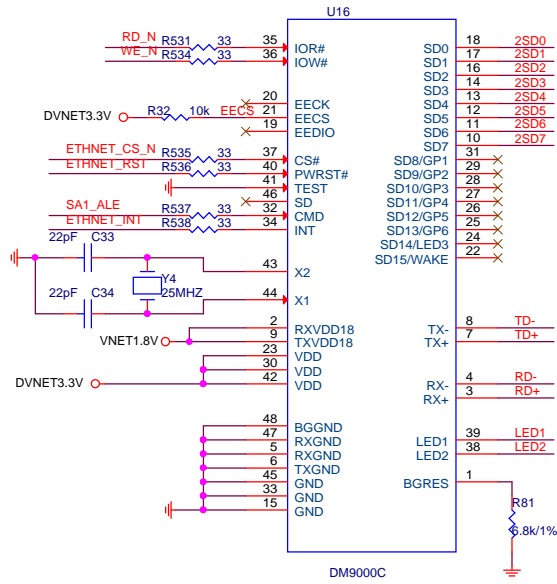

<b>INGENIC SEMICONDUCTOR CO.,LTD</b>		
Title		
<b>CI20_JZ4780</b>		
Size	Document Number	Rev
B	ETHERNET	V1.0
Date:	Thursday, June 19, 2014	Sheet 9 of 10

Data	Revision	Change
June 19 2014	Rev1.0	1. First Revision

<b>INGENIC SEMICONDUCTOR CO.,LTD</b>		
Title	<b>C120_JZ4780</b>	
Size	Document Number	Rev
B	REVISION HISTORY	V1.0
Date:	Thursday, June 19, 2014	Sheet 10 of 10